



GMB RELOADING

GMB Reloading DecapFlow automatic decapper

User manual v1.0

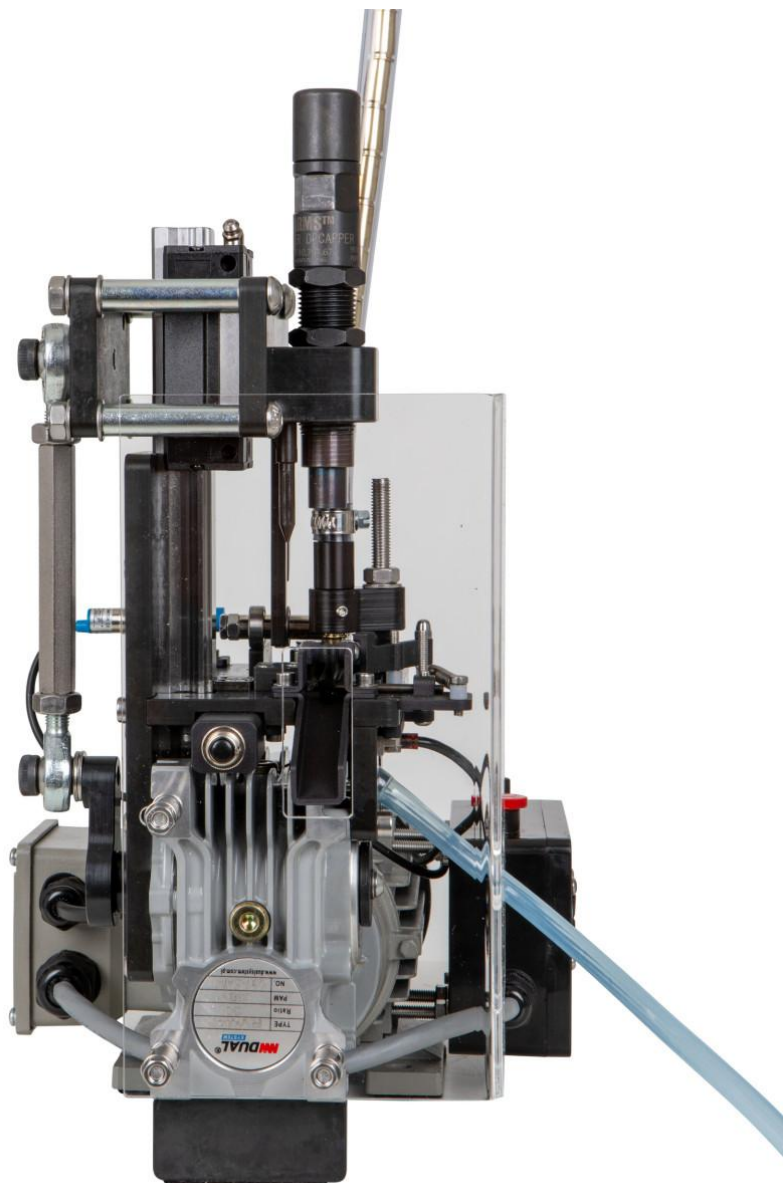

Table of Contents

Safety instructions.....	3
Set-up	4
1. Shipping contents	4
2. Drop tube mount adjustment	5
3. Hooking up the drop tube	7
4. Decapping die adjustment.....	8
5. Case pusher travel adjustment.....	11
6. Case stop spring adjustment	13
7. Left case guide tension adjustment.....	14
8. Trap door position adjustment.....	15
9. Hooking up the decapping sensors	16
10. Caliber conversion	20
Operating instructions.....	21
Maintenance	23
GMB Reloading DecapFlow limited warranty	24

Safety instructions

1. GMB Reloading shall not be liable for any damages, losses, costs or expenses, direct, indirect or incidental, consequential or special, arising out of, or related to the use of or the inability to use the product described herein. Read this manual before using this product. Failure to follow the instructions and safety precautions in this manual can result in serious injury or death.
2. GMB Reloading cannot guarantee the complete safety of the user of the GMB Reloading DecapFlow decapper. To minimize the user's risk, use common sense when using the machine and follow these basic safety rules at a minimum.
3. If you are interrupted in any manner, stop the machine.
4. Do not remove any safety device(s) from the machine or modify it in any way.
5. Keep your hands and clothing clear of the moving parts of the machine while it is in operation.
6. If you are unsure about the safe operation of the machine, seek guidance from a qualified professional or the manufacturer.
7. If the machine is damaged or malfunctioning in any way, do not use it and have it repaired by a qualified professional.

Set-up

1. Shipping contents

- GMB Reloading DecapFlow decapper
- M6 bolt

Caliber conversion kits and primer detection sensors are sold separately.

2. Drop tube mount adjustment

Turn off the machine. Unscrew the upper shoulder bolt (1) while holding the head (2). **Do not remove the head from the rail.** There is a spacer sleeve between the rod end (3) and the head. One side of the spacer sleeve is chamfered - keep this in mind during reassembly. Lower the head all the way down.

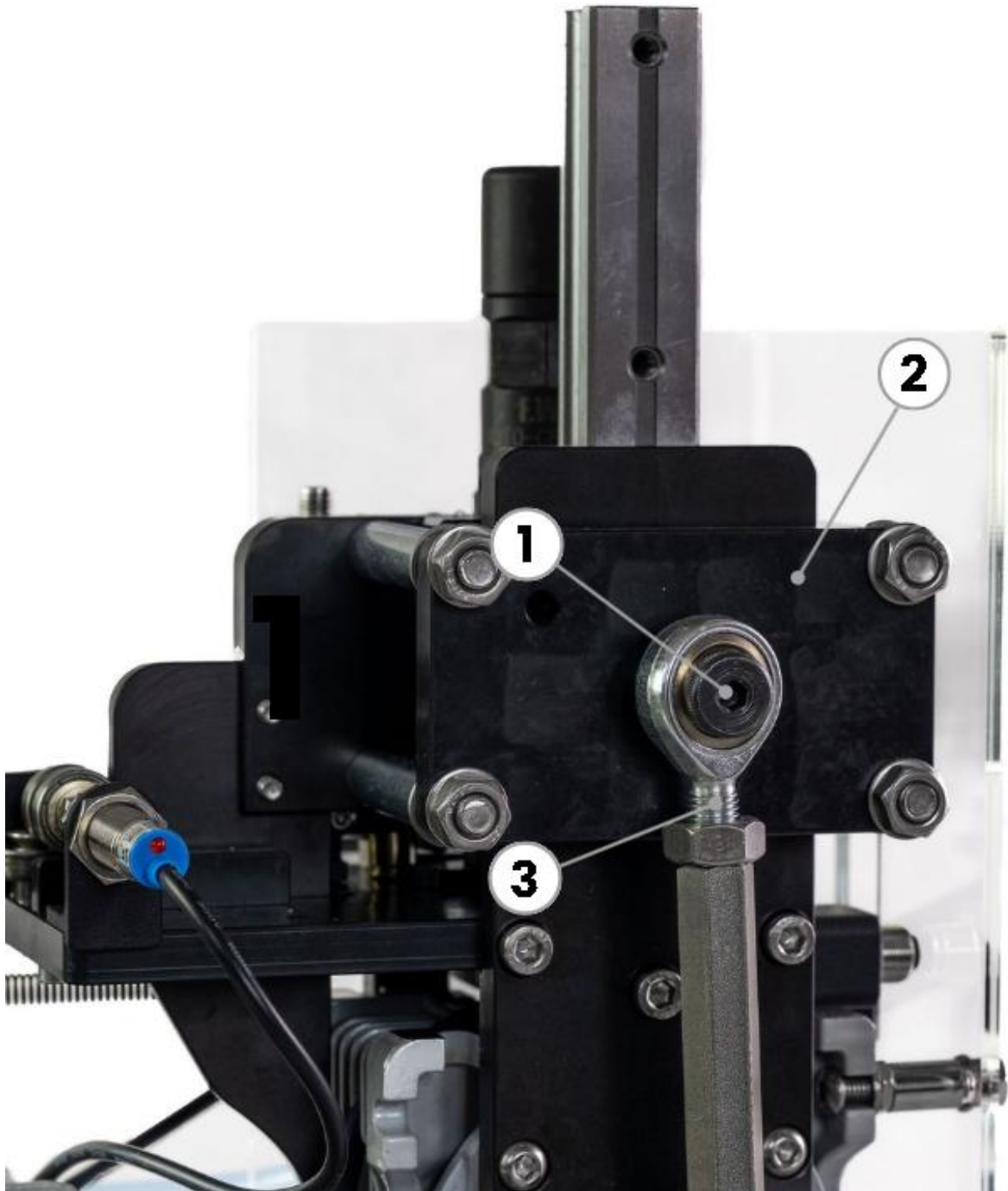

Align the drop tube mount (4) as shown below, then tighten the nut (5).

Make sure that the head won't hit the tube mount!

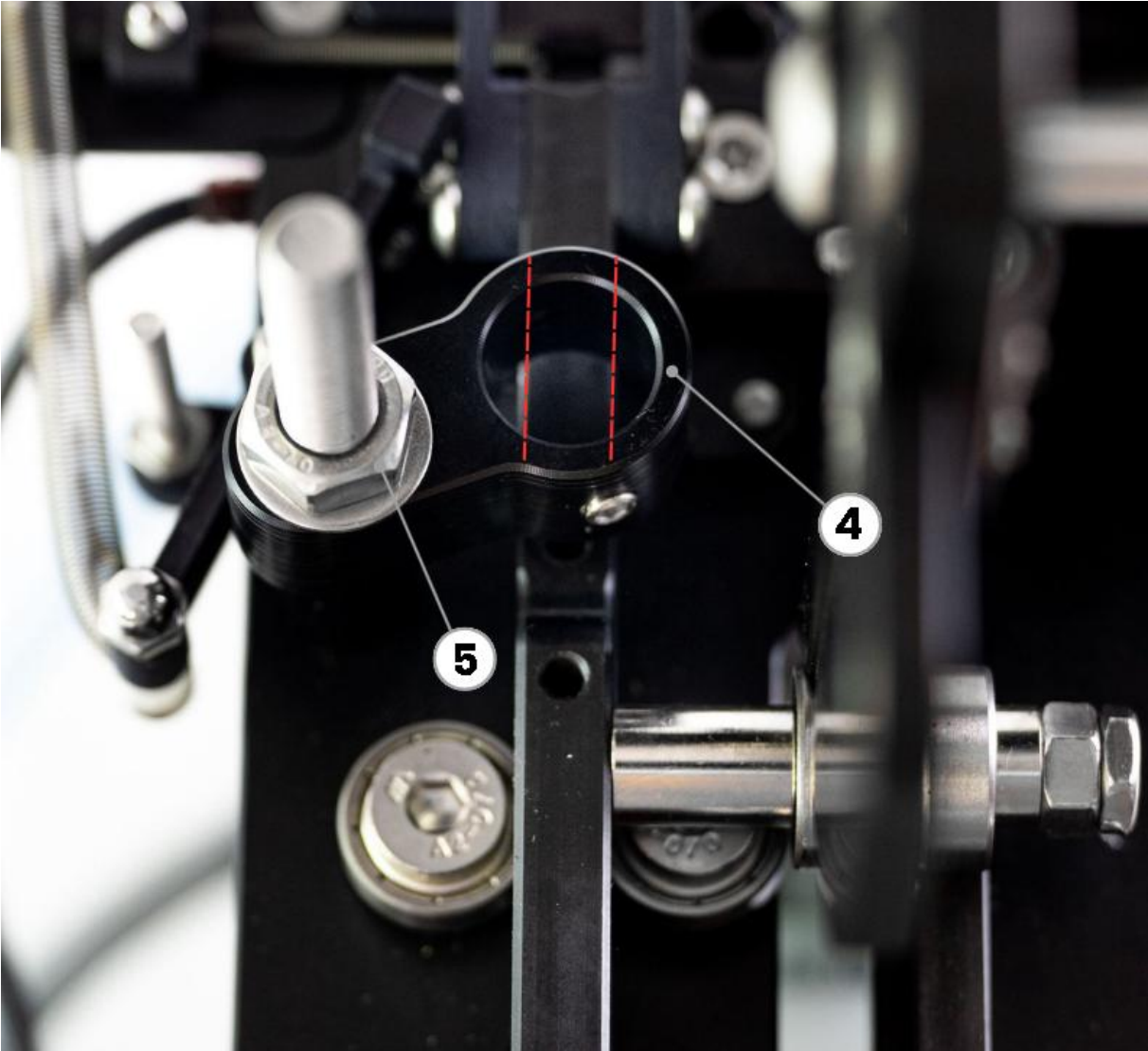

3. Hooking up the drop tube

Connect the drop tube (1) to the drop tube mount (2), then tighten the two M5 set screws. **Make sure that the worm drive clamp screw is on the right side!**

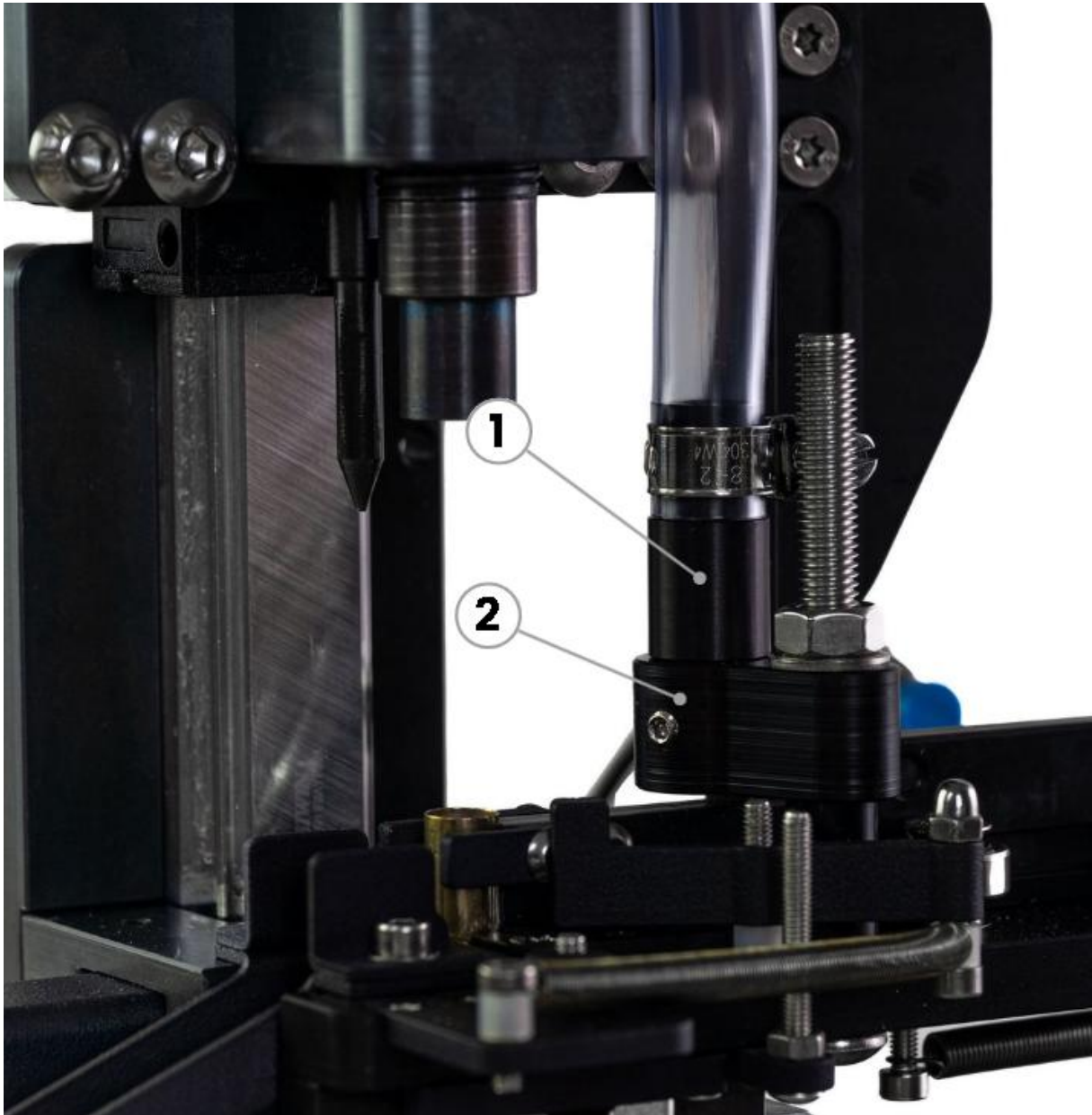

4. Decapping die adjustment

We strongly recommend using decapping dies that feature some form of case guide to keep the case centered and vertical.

Turn off the machine and remove the shield. While holding the head (1), unscrew the upper shoulder bolt (2). Then lower the head all the way down.

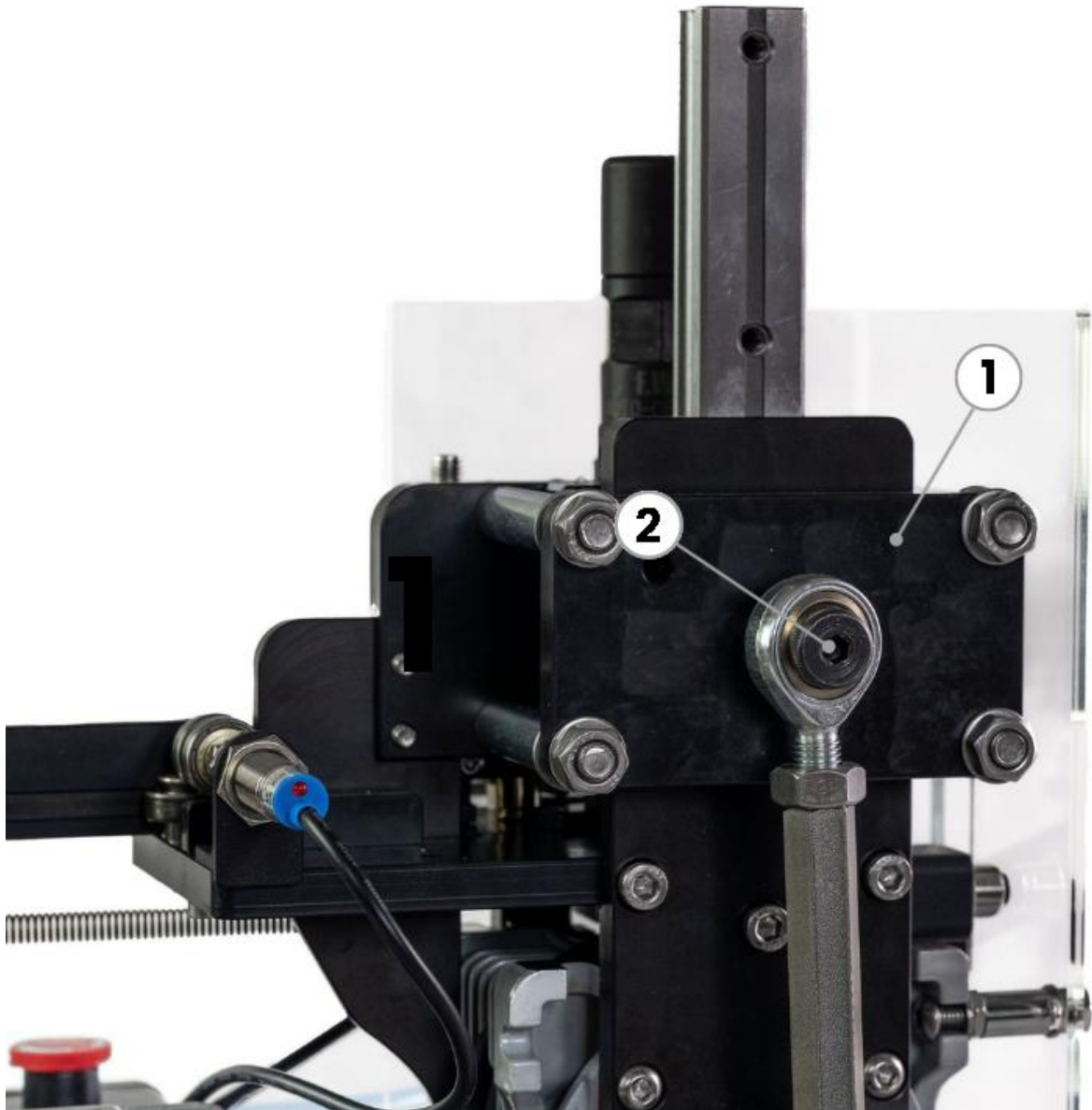

Using the provided M6 bolt (3), secure the head in place as shown below.

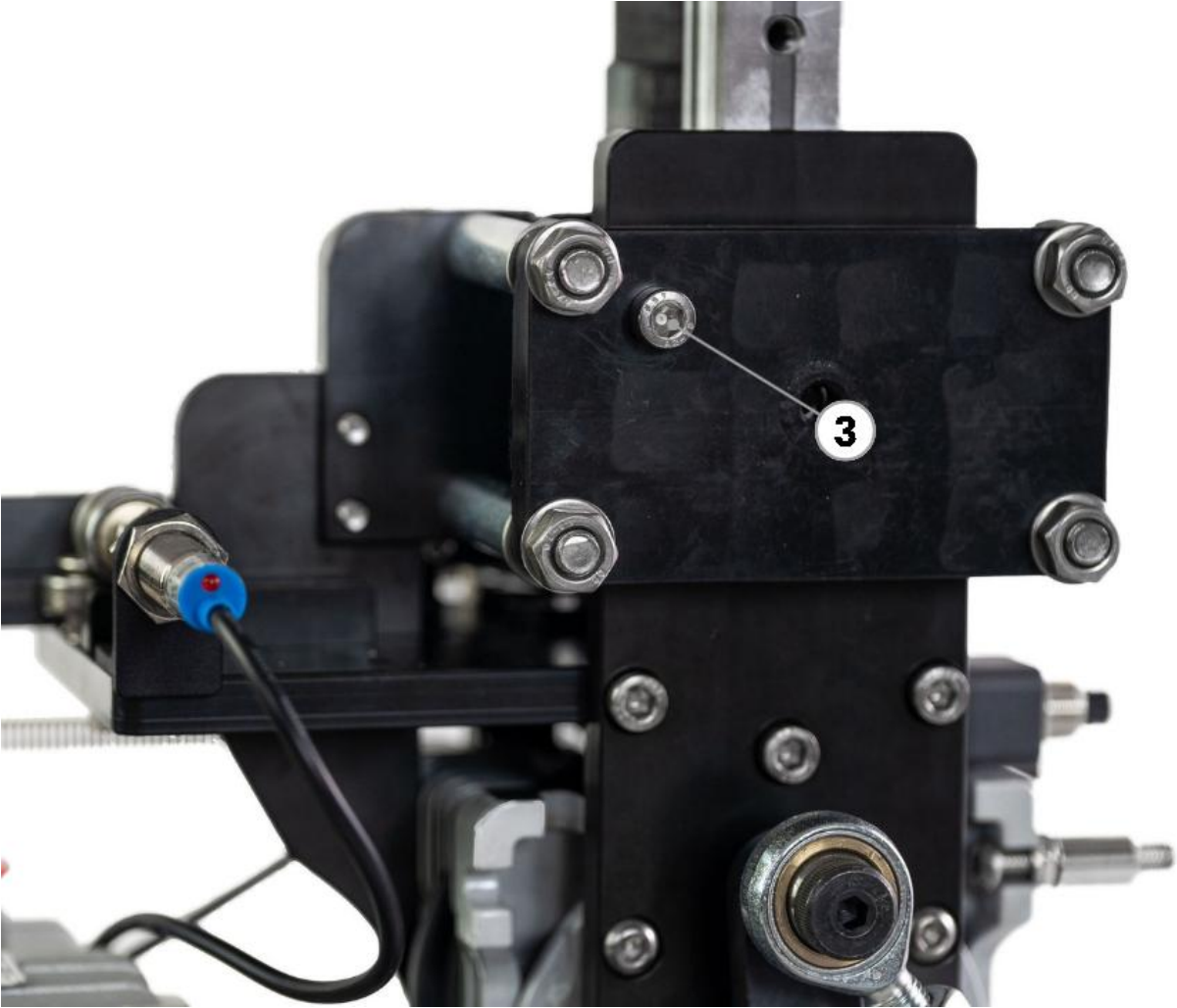

Screw the decapping die body all the way down until it touches the case guides (4), then back it off one turn. Secure the die in place by tightening the lock nut.

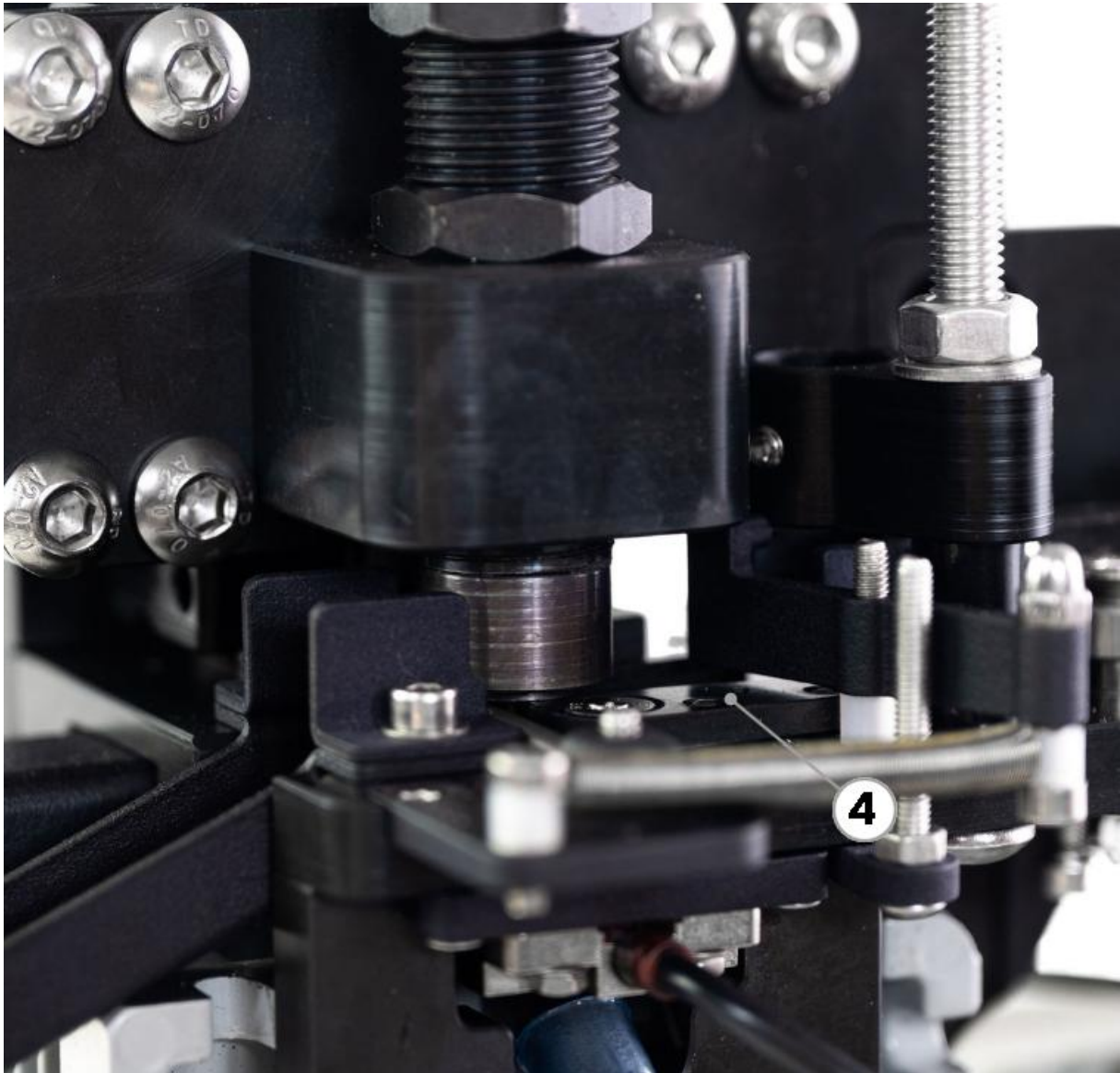

Remove the M6 bolt and connect the head to the upper rod end using the shoulder bolt. Be sure to install the spacer sleeve.

5. Case pusher travel adjustment

Turn off the machine. Disconnect the case pusher spring and loosen the two countersunk M5 bolts (1). You can now move the cam (2) to the left or right. Place the cam spacer (3) provided with the conversion kit between the cam and the front head plate (4), as shown below. The spacer marked “.45 ACP” is for .45 ACP and .308 Win

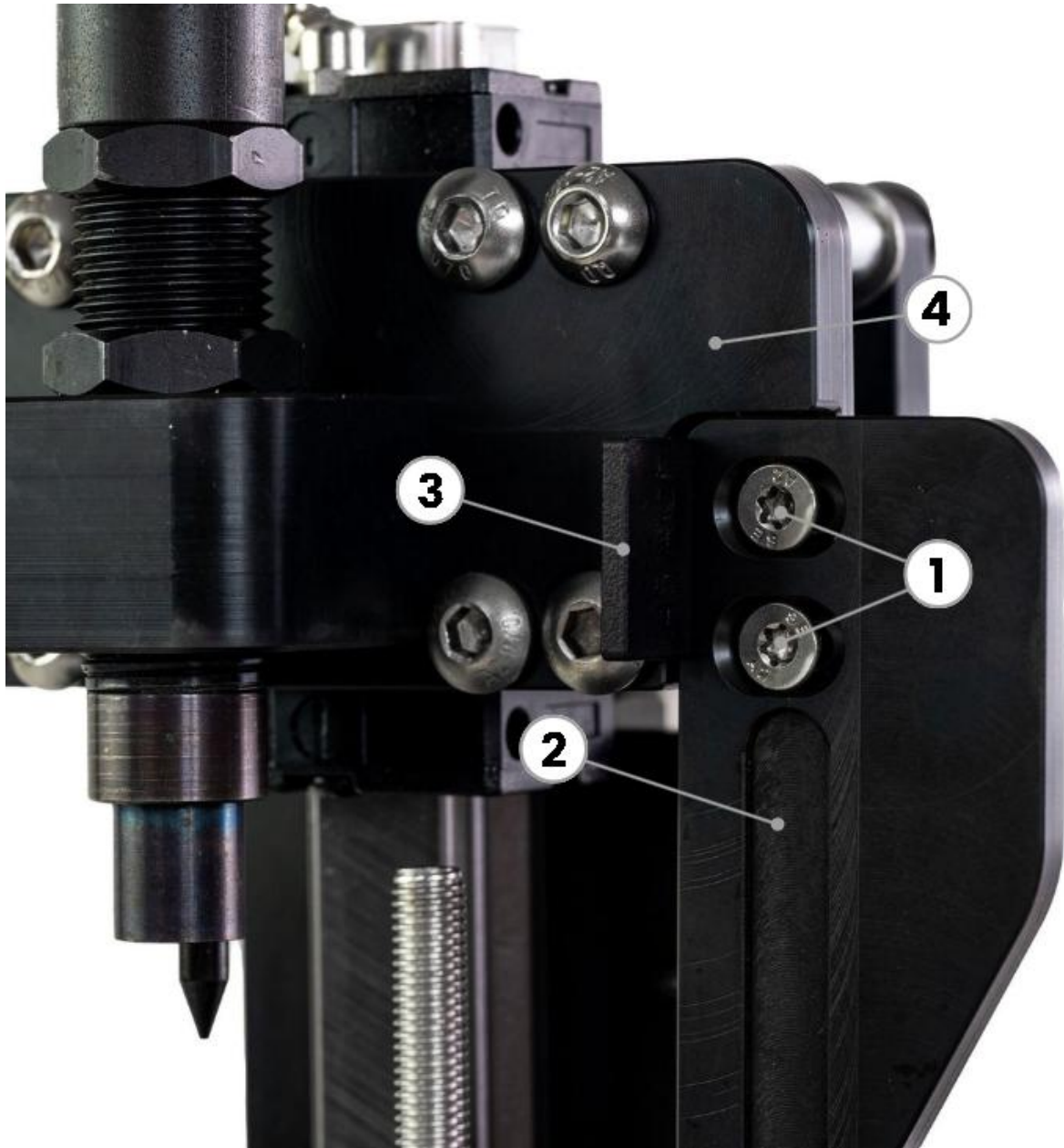

For larger-diameter cases like .308 or .45 ACP, the cam should be positioned further to the right. For smaller-diameter cases like .223 or 9mm, it should be positioned more to the left. The cam's position determines how far the case pusher will travel.

Ensure that the cam remains vertical in relation to the front head plate. Push the cam fully to the left against the cam spacer, then tighten the two M5 countersunk bolts. **Remove the spacer.**

Reconnect the case pusher spring, feed one case into the tube, and cycle the machine. Check whether the case stops directly under the decapping die. Repeat the adjustment process if necessary.

If you are using decapping sensors, make sure to verify the position of the proximity sensor.

6. Case stop spring adjustment

The case stop spring (1) ensures that the case always stops under the decapping die. Loosen the M4 set screw (2) and adjust the case stop spring based on the caliber you are working with. For larger diameter cases, such as .308 or .45 ACP, you should move it back slightly.

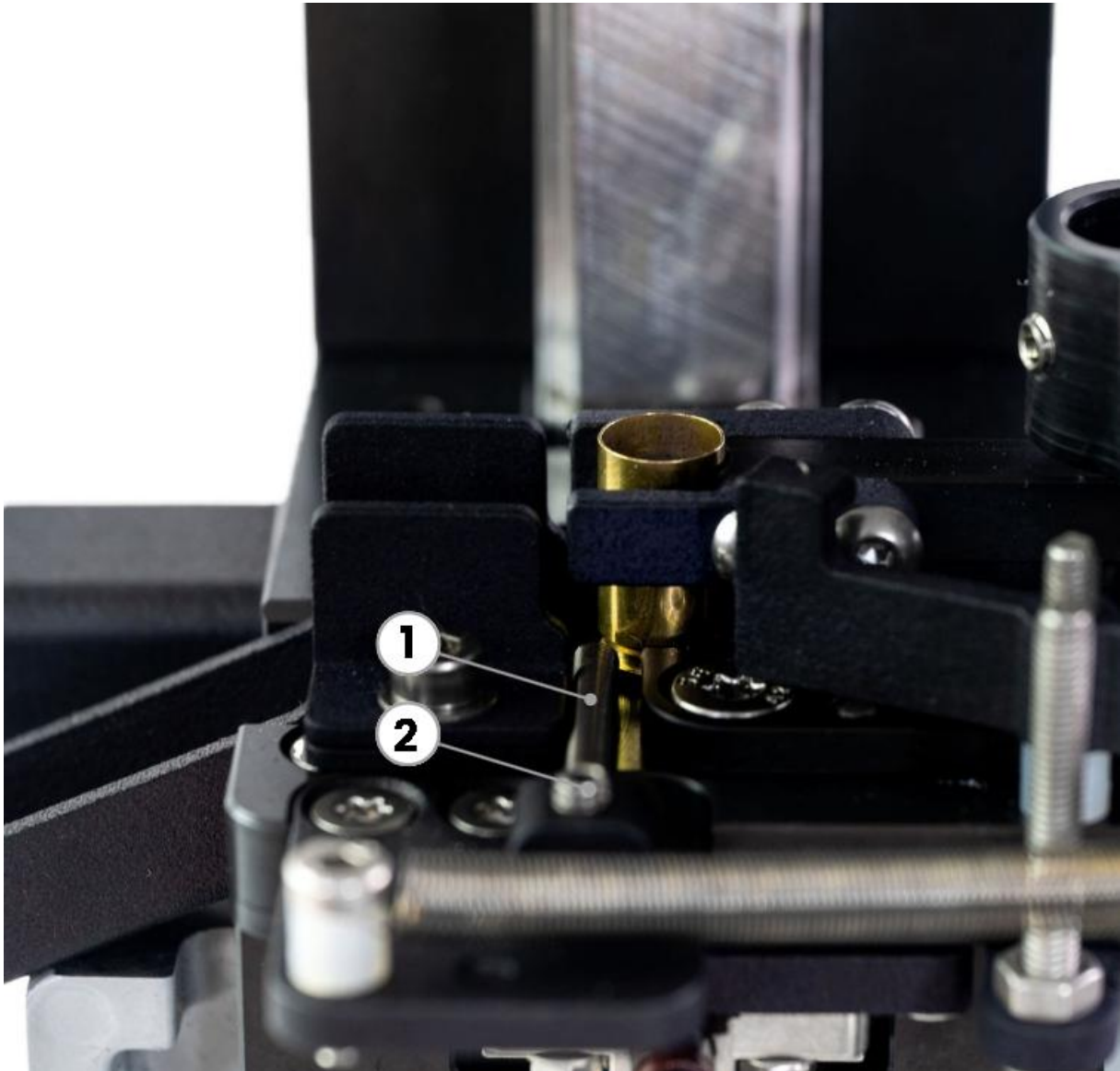

7. Left case guide tension adjustment

This is likely the only adjustment you'll never need to make. The tensioning feature is included because the rim of the case can vary, and the case guides can adapt to accommodate different rim diameters. If you need to adjust the friction between the case guides and the case, this adjustment allows you to do so.

Loosen the two M4 countersunk bolts and move the tension block (1) to the right to increase tension, or to the left to decrease tension. A feeler gauge can be helpful - insert it between the tension block and the rail (2), then tighten the two M4 countersunk bolts.

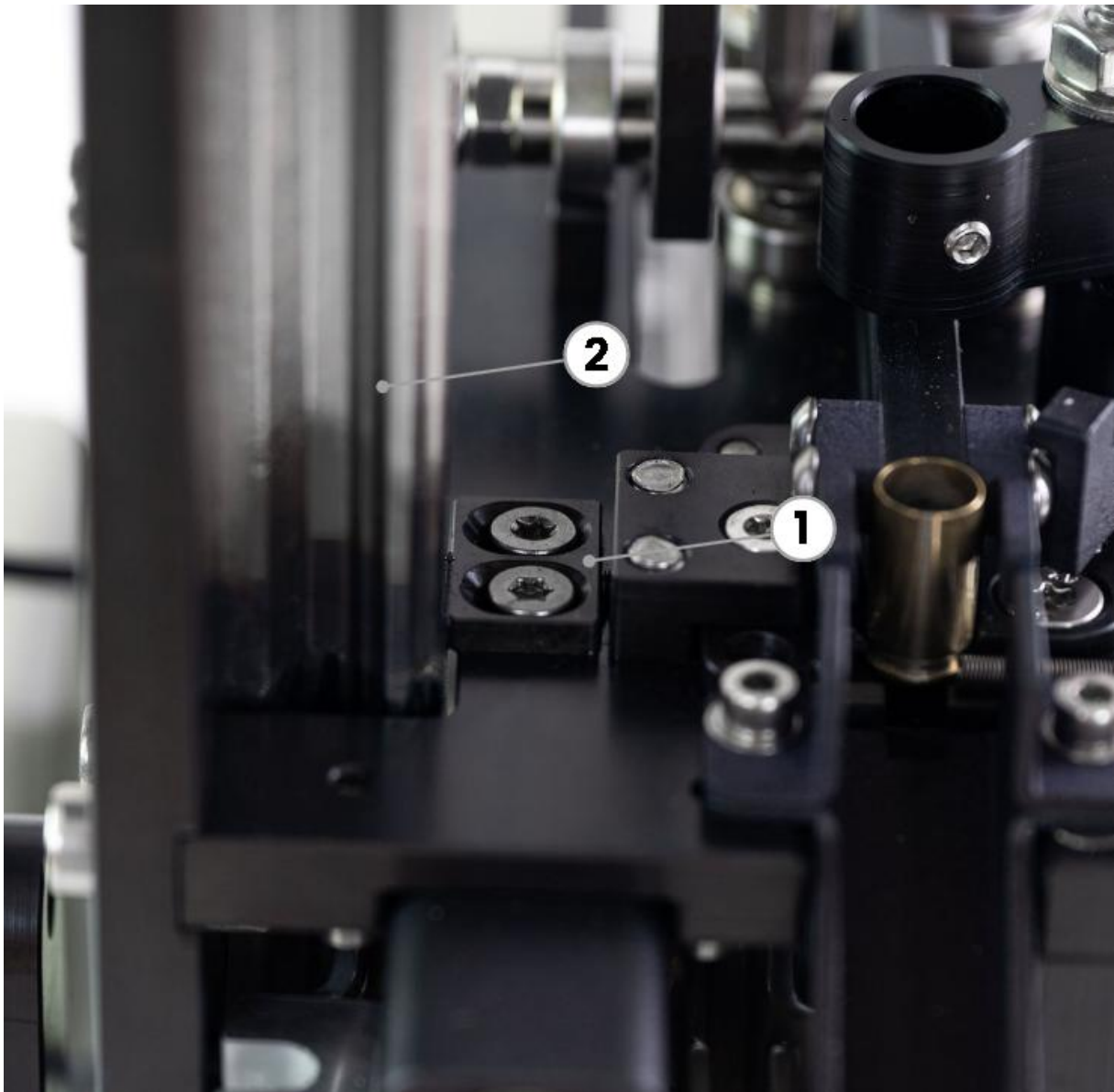

8. Trap door position adjustment

Loosen the M4 bolt (1) and move the trap door stop (2) to the left if you want the trap door closer to the case pusher (for cases like 9mm or .223), or to the right if you want it further from the case pusher (for cases like .308 or .45 ACP).

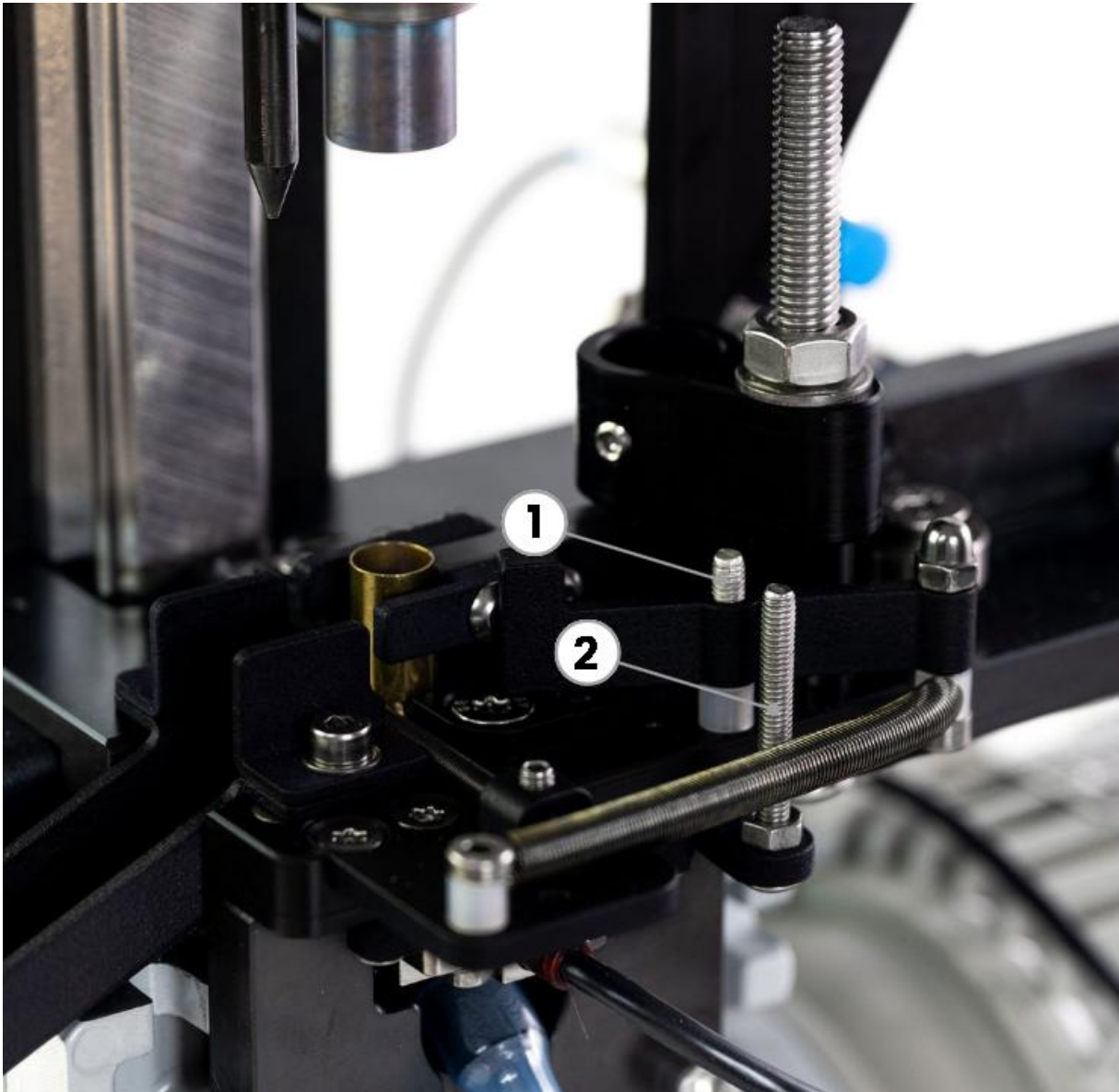

9. Hooking up the decapping sensors

Unplug the machine from the power source. Unscrew the upper shoulder bolt (1) while holding the head (2). Then, lower the head all the way down.

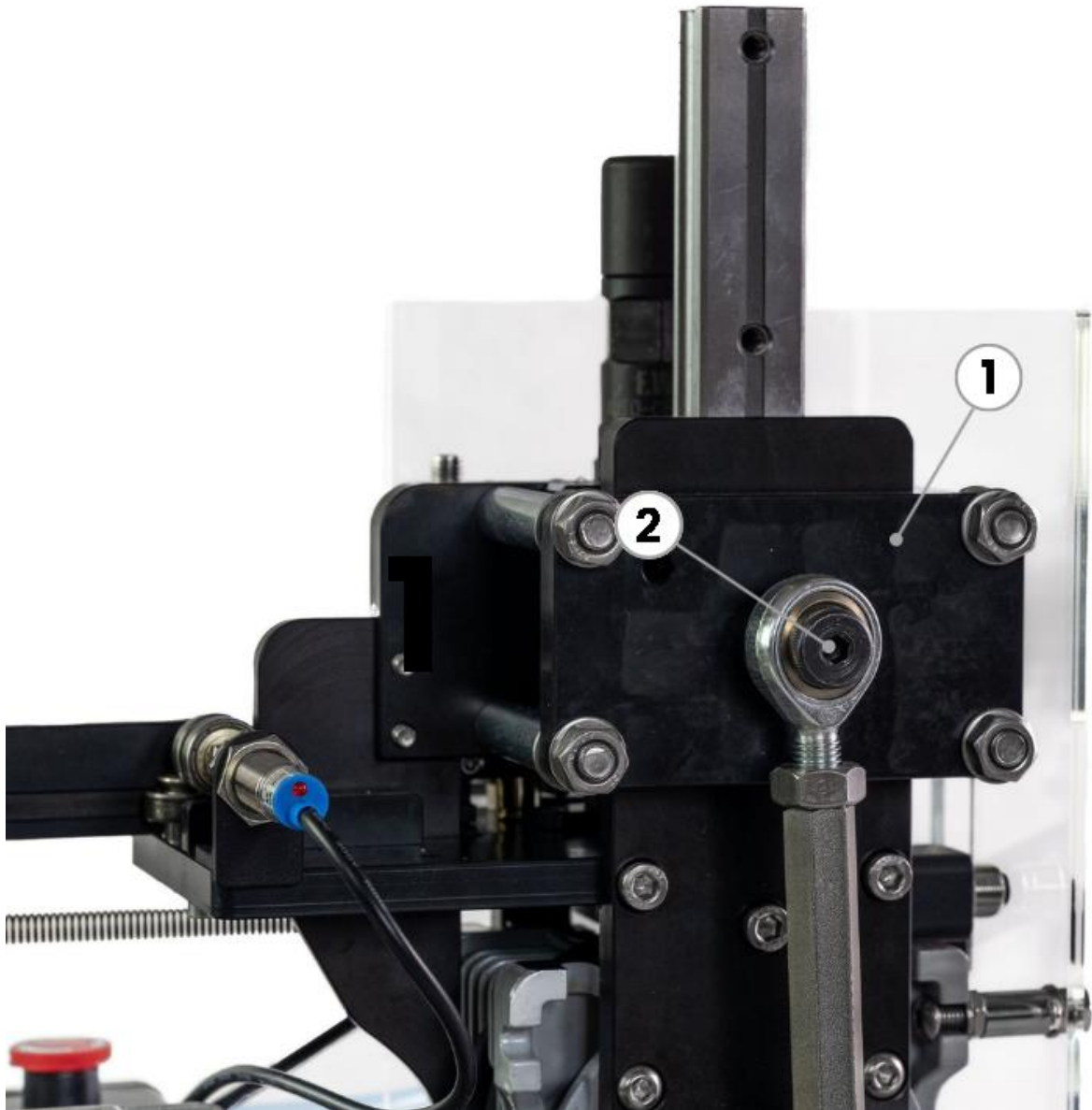

Insert the connector into the socket and mount the cable shield using two M4 bolts.

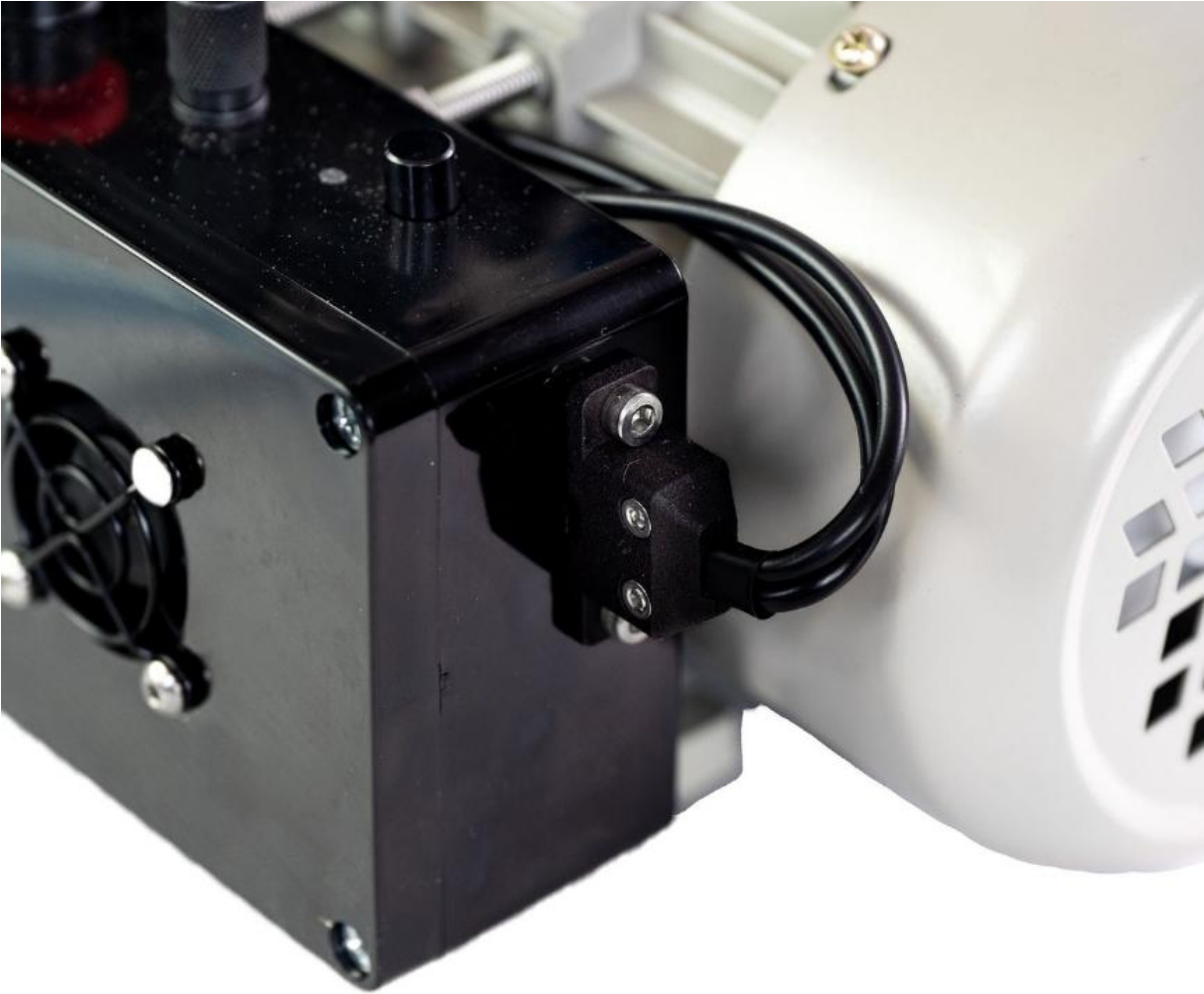

Remove the shield. Using the M4 bolt, mount the proximity sensor so that the pusher rod (3) is aligned with the sensor's face. Ensure that the gap between the sensor and the rod is about 2mm.

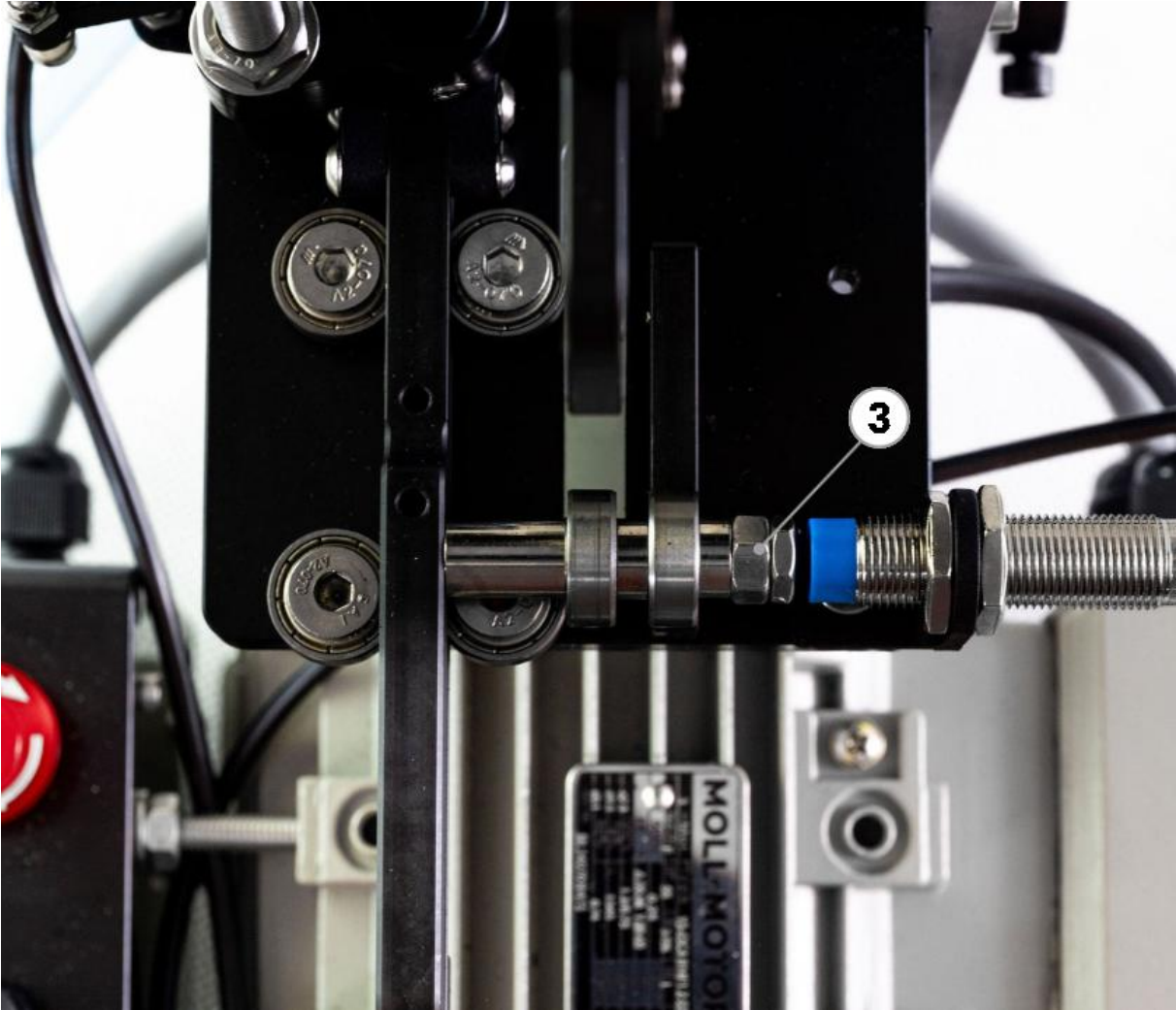

Mount the fork sensor to the base using two M3 countersunk bolts, as shown below.

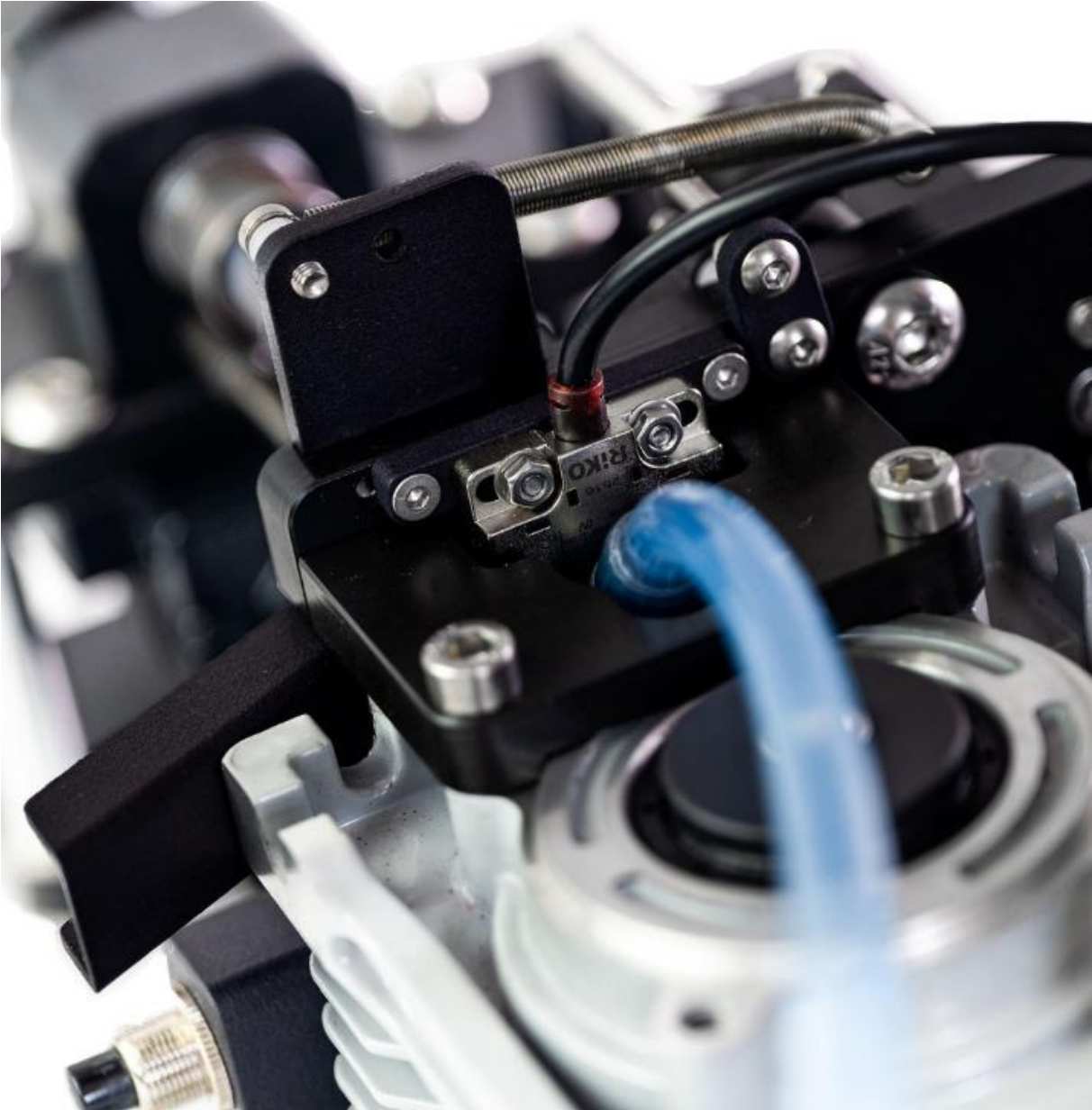

Mount the shield and turn the machine on.

10. Caliber conversion

Stop the head at the top of its stroke. Remove the shield. Detach the trap door (1) by pulling it upwards. Disconnect the case pusher spring and move the case pusher to the right. Unscrew the M5 countersunk bolt and remove the right case guide (2). A dental pick might come in handy. Loosen the M4 countersunk bolt (3) and pivot the left case guide (4) to the right, then remove it. Replace the case guides, ensuring that the left case guide is spring-loaded. Install the trap door arm. Replace the drop tube and drop tube mount if necessary. Replace the spacer sleeve (5) (20mm for 9mm, 24mm for .45 ACP and .40 S&W, 46mm for .223, and 53mm for .308). Mount the case pusher riser (6) (for rifle calibers). Connect the case pusher spring.

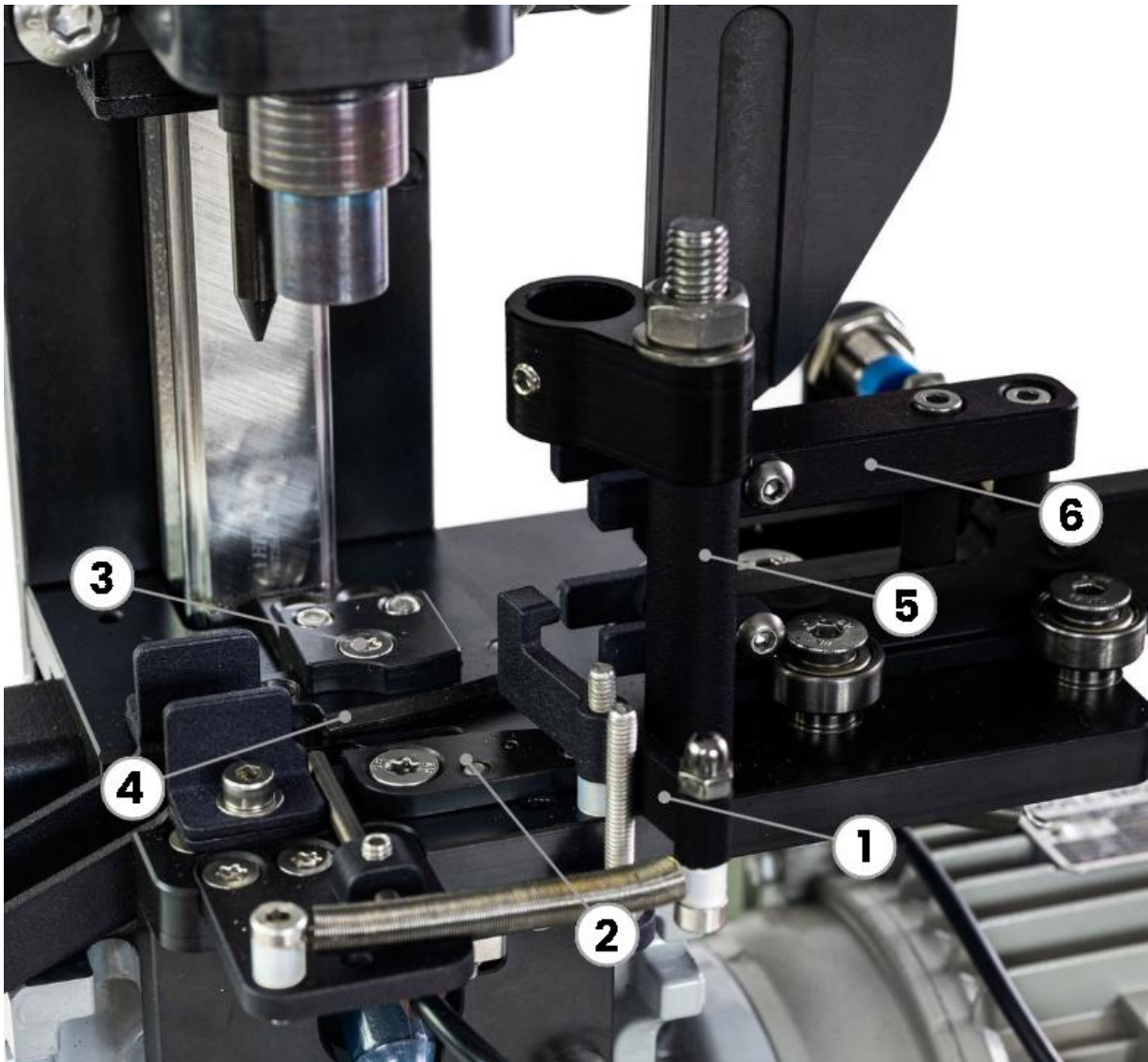

Operating instructions

For optimal performance, the machine should be operated in an environment with a minimum room temperature of 20 °C (68 °F).

Turn the machine on and off using the safety switch (1). Increase the operating speed by turning the knob (2) clockwise. Start the machine by pressing down on the switch (3).

If there is a jam, the diode (4) will turn red, and the machine will stop and begin beeping. Simply press the switch (3) to clear the jam. Turn off the machine by pressing the safety switch (1) and wait until the diode turns off. To turn the machine on, rotate the safety switch clockwise.

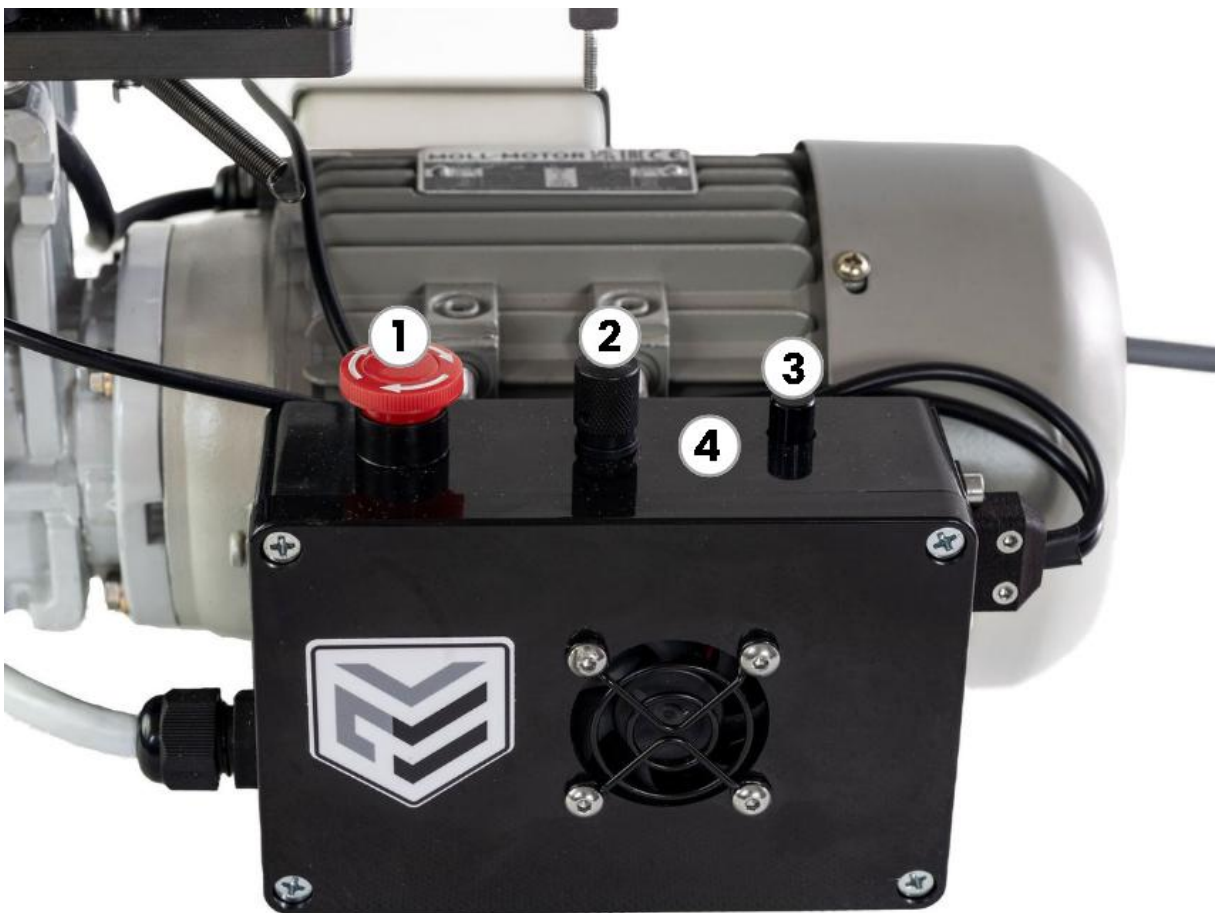

Decapping sensors

The decapping sensors begin detecting primers after the first primer passes through the fork sensor. If no primer is detected, the diode (4) will turn blue, and the machine will stop. Press the switch (3) to move the head to the desired position. Inspect the case. Turn off the machine by pressing the safety switch (1) and wait until the diode turns off. To turn the machine on, rotate the safety switch clockwise. Start the machine by pressing the switch (3).

Maintenance

Occasionally grease the linear guide rail using the grease nipple. Apply a drop of oil to each bearing. Ensure that the primer tube and funnel are free of any debris.

GMB Reloading DecapFlow limited warranty

GMB Reloading offers a two-year warranty for the GMB Reloading DecapFlow decapping machine, starting from the date of shipment. This warranty covers defects in material and workmanship. However, there are specific components that have a one-year warranty against defects in material and workmanship from the date of shipment. These components include:

- DC motor
- worm gearbox

GMB Reloading

Komornicka 34A/6

62-069 Dąbrówka, Poland

<https://gmbreloading.pl/>

info@gmbreloading.pl